



ETA-Danmark A/S
Göteborg Plads 1
DK-2150 Nordhavn
Tel. +45 72 24 59 00
Fax +45 72 24 59 04
Internet www.eta danmark.dk

Authorised and notified according
to Article 29 of the Regulation (EU)
No 305/2011 of the European
Parliament and of the Council of 9
March 2011

MEMBER OF EOTA



European Technical Assessment ETA-21/0421 of 2021/05/28

I General Part

Technical Assessment Body issuing the ETA and designated according to Article 29 of the Regulation (EU) No 305/2011: ETA-Danmark A/S

Trade name of the construction product:

Fastening Screws JF

Product family to which the above construction product belongs:

Fastening screws for metal members and sheeting

Manufacturer:

EJOT Baubefestigungen GmbH
Geschäftsbereich Building Fasteners
In der Stockwiese 35
DE-57334 Bad Laasphe
Internet www.ejot.de/bau

Manufacturing plant:

Manufacturing plants 8, 13 and 53

This European Technical Assessment contains:

21 pages including 15 annexes which form an integral part of the document

This European Technical Assessment is issued in accordance with Regulation (EU) No 305/2011, on the basis of:

EAD 330046-01-0602, Fastening Screws for Metal Members and Sheeting

This version replaces:

Translations of this European Technical Assessment in other languages shall fully correspond to the original issued document and should be identified as such.

Communication of this European Technical Assessment, including transmission by electronic means, shall be in full. However, partial reproduction may be made, with the written consent of the issuing Technical Assessment Body. Any partial reproduction has to be identified as such.

II SPECIFIC PART OF THE EUROPEAN TECHNICAL ASSESSMENT

1 Technical description of the product

The fastening screws for metal members and sheeting (self-drilling screws) are made of steel. The fastening screws are completed with a metallic washer and an EPDM sealing washer. The fastening screws for metal members and sheeting are made of a bimetal combination of austenitic stainless with drill bits made of carbon steel.

Table 1 – Fastening screws of the corresponding ETA and their field of application

Annex	Fastening screw	Component I	Component II
5	JF3-(FR-)4.9xL JF6-(FR-)4.9xL	S280GD to S350GD	Timber
6	JF3-(FR-)4.9xL JF6-(FR-)4.9xL	S280GD to S350GD	Timber
7	JF3-(FR-)4.9xL JF6-(FR-)4.9xL	Aluminium $R_m \geq 165 \text{ N/mm}^2$	Timber
8	JF3-(FR-)4.9xL JF6-(FR-)4.9xL	Aluminium $R_m \geq 165 \text{ N/mm}^2$	Timber
9	JF3-(FR-)4.9xL JF6-(FR-)4.9xL	Aluminium $R_m \geq 215 \text{ N/mm}^2$	Timber
10	JF3-(FR-)4.9xL JF6-(FR-)4.9xL	Aluminium $R_m \geq 215 \text{ N/mm}^2$	Timber
11	JF3-(FR/LT-)2-6.0xL JF6-(FR/LT-)2-6.0xL	S280GD to S350GD	S280GD to S350GD
12	JF3-(FR/LT-)2-6.0xL JF6-(FR/LT-)2-6.0xL	S280GD to S350GD	S280GD to S350GD
13	JF3-(FR/LT-)2-6.0xL JF6-(FR/LT-)2-6.0xL	Aluminium $R_m \geq 165 \text{ N/mm}^2$	Aluminium $R_m \geq 165 \text{ N/mm}^2$
14	JF3-(FR/LT-)2-6.0xL JF6-(FR/LT-)2-6.0xL	Aluminium $R_m \geq 215 \text{ N/mm}^2$	Aluminium $R_m \geq 215 \text{ N/mm}^2$
15	JF3-(FR/LT-)2-6.0xL JF6-(FR/LT-)2-6.0xL	Aluminium $R_m \geq 215 \text{ N/mm}^2$	S280GD to S350GD

2 Specification of the intended use in accordance with the applicable EAD 330046-01-0602

The fastening screws are intended to be used for fastening metal sheeting made of steel according to EN 10346 or aluminium alloy according to EN 485 or EN 573 to substructures made of steel according to EN 10025 or EN 10346, aluminium alloy according to EN 485 or EN 573 or structural timber according to EN 14081. The sheeting can either be used as wall or roof cladding or as load bearing wall and roof element. The fastening screws can also be used for the fastening of any other thin gauge metal members. The intended use comprises fastening screws and connections for indoor and outdoor applications.

Fastening screws which are intended to be used in external environments with \geq C2 corrosion according to the standard EN ISO 12944-2 are made of stainless steel. Furthermore, the intended use comprises connections with predominantly static loads (e.g. wind loads, dead loads). The fastening screws are not intended for re-use.

The performances given in Section 3 are only valid if the fastening screws are used in compliance with the specifications and conditions given in Annex 1 to 15.

The provisions made in this European Technical Assessment are based on an assumed intended working life of the screws of 25 years.

The indications given on the intended working life cannot be interpreted as a guarantee given by the producer or the Technical Assessment Body, but are to be regarded only as a means for selecting the appropriate products in relation to the expected economically reasonable working life of the works.

The real working life might be, in normal use conditions, considerably longer without major degradation affecting the Basic requirements for construction works.

3 Performance of the product and references to the methods used for its assessment

Performances of the fasteners, related to the basic requirements for construction works (hereinafter BWR), were determined according to EAD 330046-01-0602.

These performances, given in the following paragraphs, are valid as long as the components are the ones described in § 1 and Annexes 1 to 15 of this ETA.

Characteristic	Assessment of characteristic
3.1 Mechanical resistance and stability (BWR 1)	
Shear Resistance of the Connection	See Annexes to this ETA
Tension Resistance of the Connection	See Annexes to this ETA
Design Resistance in case of combined Tension and Shear Forces (interaction)	See Annex 2 to this ETA
Check of Deformation Capacity in case of constraining forces due to temperature	See Annex 2 to this ETA
Durability	See Annex 4 to 20, material of the fasteners
3.2 Safety in case of fire (BWR2)	
Reaction to fire	The screws are made from steel classified as Euroclass A1 in accordance with EN 13501-1 and Commission Delegated Regulation 2016/364

4 Attestation and verification of constancy of performance (AVCP)

4.1 AVCP system

According to the decision 1998/214/EC of the European Commission 1, as amended by 2001/596/EC, the system of assessment and verification of constancy of performance (see Annex V to Regulation (EU) No 305/2011) is:

2+

5 Technical details necessary for the implementation of the AVCP system, as foreseen in the applicable EAD

Technical details necessary for the implementation of the AVCP system are laid down in the control plan deposited at ETA-Danmark prior to CE marking.

Issued in Copenhagen on 2021-05-28 by



Thomas Bruun
Managing Director, ETA-Danmark

Examples of execution and connection

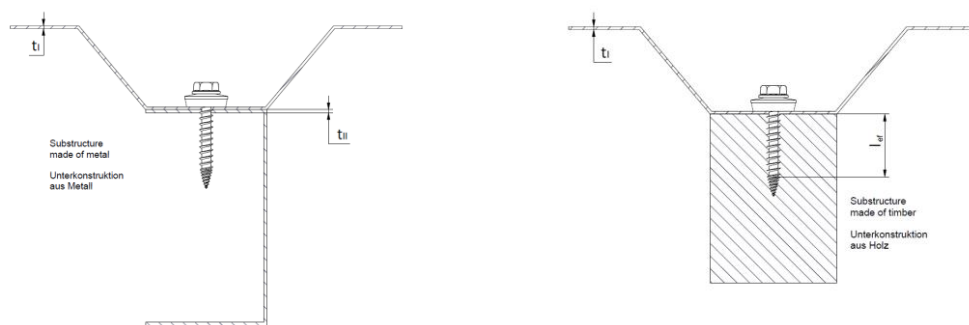

Materials and dimensions

Design relevant materials and dimensions are indicated in the Annexes of the fastening screws:

Fastener	Material of the fastening screw
Washer	Material of the sealing washer
Component I	Material of the metal member and sheeting
Component II	Material of the substructure

$t_{N,I}$	Thickness of component I
$t_{N,II}$	Thickness of component II made of metal
l_{ef}	Effective screw-in length in component II made of timber (without drill point)
l_g	Screw-in length in component II made of timber (with drill point)
l_b	Length of drill point
d_{pd}	Pre-drill diameter of component I and II
$M_{t,nom}$	Tightening torque of the fastening screw

The thickness $t_{N,II}$ corresponds to the load-bearing screw-in length of the fastening screw in component II, if the load-bearing screw-in length does not cover the entire component thickness.

Performance characteristics

The design relevant performance characteristics of a connection are indicated in the Annexes of the fastening screws.

$N_{R,k}$	Characteristic value of tension resistance
$V_{R,k}$	Characteristic value of shear resistance

In some cases component-specific performance characteristics are indicated for an individual calculation in the design relevant performance characteristics of a connection:

$N_{R,I,k}$	Characteristic value of pull-through resistance for component I
$N_{R,II,k}$	Characteristic value of pull-out resistance for component II
$V_{R,I,k}$	Characteristic value of hole bearing resistance for component I
$V_{R,II,k}$	Characteristic value of hole bearing resistance for component II

$M_{y,Rk}$	Characteristic value of yield moment of the fastening screw (for component II made of timber)
$f_{ax,k}$	Characteristic value of withdrawal strength for component II made of timber
$f_{h,k}$	Characteristic value of embedding strength for component II made of timber

Fastening screws JF

Terms and explanations

Annex 1

Occurred loadings of a connection

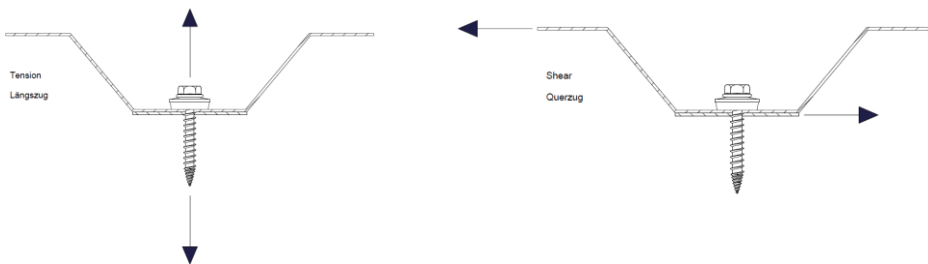

Design values

The design values of tension and shear resistance of a connection have to be determined as following:

- $N_{R,d}$ Design value of tension resistance
- $V_{R,d}$ Design value of shear resistance
- γ_M Partial safety factor

The recommended partial safety factor γ_M is 1,33, provided no partial safety factor is given in national regulations or national Annexes to Eurocode 3.

Special conditions

If the component thickness $t_{N,I}$ or $t_{N,II}$ lies in between two indicated component thicknesses, the characteristic value may be calculated by linear interpolation.

For asymmetric components II made of metal (e.g. Z- or C-shaped profiles) with component thickness $t_{N,II} < 5$ mm, the characteristic value $N_{R,k}$ has to be reduced to 70%.

In case of combined loading by tension and shear forces the following interaction equation has to be taken into account:

$$\frac{N_{S,d}}{N_{R,d}} + \frac{V_{S,d}}{V_{R,d}} \leq 1,0$$

- $N_{S,d}$ Design value of the applied tension forces
- $V_{S,d}$ Design value of the applied shear forces

Types of connection

For the types of connection (a,b,c,d) given in the Annexes of the fastening screws, it is not necessary to take into account the effect of constraints due to temperature. For other types of connection the effect of constraints have to be taken into account, unless they do not occur are not significant (e.g. sufficient flexibility of the substructure).

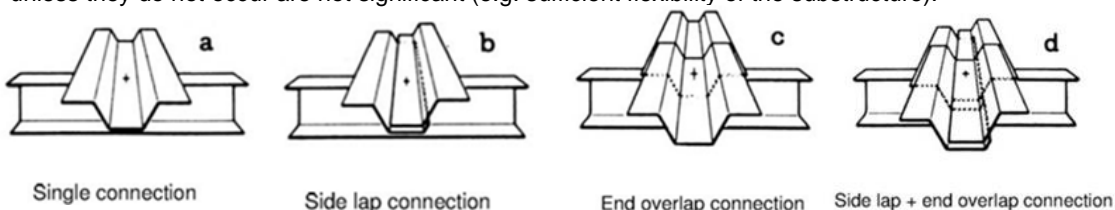

Installation conditions

- The installation is carried out according to manufacturer`s instruction.
- The load-bearing screw-in length of the fastening screw specified by the manufacturer has to be taken into account.
- The fastening screws have to be processed with suitable drill driver (e.g. cordless drill driver with depth control). The use of impact wrench is not allowed.
- The fastening screws have to be fixed rectangular to the surface of the component.
- Component I and component II have to be in direct contact to each other. The use of compression resistant thermal insulation strips up to a thickness of 3 mm is allowed.

Fastening screws JF	Annex 2
Design and installation	

Component I made of perforated sheeting

The characteristic values of tension and shear resistance are determined as follows:

$$N_{R,k} = \min \left\{ \begin{array}{l} N_{R,I,k} \\ N_{R,II,k} \end{array} \right. \quad V_{R,k} = \min \left\{ \begin{array}{l} V_{R,I,k} \\ V_{R,k} \end{array} \right.$$

$N_{R,I,k}$ and $V_{R,I,k}$ are given in Annex 4 to 7.

$N_{R,II,k}$ and $V_{R,k}$ are given in the Annex of the fastening screw.

Component I made of aluminium alloy

The characteristic value of tension resistance is determined as follows:

$$N_{R,k} = \min \left\{ \begin{array}{l} N_{R,I,k} \\ N_{R,II,k} \end{array} \right.$$

$N_{R,I,k}$ is determined according to EN 1999-1-4:2007 + AC:2009, equation (8.13).

$N_{R,II,k}$ is given in the Annex of the fastening screw.

Component II made of timber

The characteristic values of tension and shear resistance for other k_{mod} or ρ_k as indicated in the Annex of the fastening screw can be determined as follows:

$$N_{R,k} = \min \left\{ \begin{array}{l} N_{R,I,k} \\ N_{R,II,k} * k_{mod} \end{array} \right. \quad V_{R,k} = \min \left\{ \begin{array}{l} V_{R,I,k} \\ V_{R,II,k} * k_{mod} \end{array} \right.$$

$N_{R,I,k}$ and $V_{R,I,k}$ are given in the Annex of the fastening screw.

$N_{R,II,k}$ is determined according to EN 1995-1-1:2014 + A1:2008, equation (8.40a), with $f_{ax,k}$ given in Annex of the fastening screw.

$V_{R,II,k}$ is determined according to EN 1995-1-1:2014 + A1:2008, equation (8.9), with $M_{Y,Rk}$ given in the Annex of the fastening screw and $f_{h,k}$ according to EN 1995-1-1:2014 + A1:2008, equation (8.15).

Fastening screws JF

Additional provisions

Annex 3

Screws			Head or disc diameter d_w in [mm]			
			14	16	19	22
Pull-through resistance $N_{R,I,K}$ in [kN]	Component I: t_i in [mm], Aluminium Tensile strength $R_m \geq 165$ N/mm ²	0.50	0.43	0.46	0.5	0.54
		0.60	0.51	0.55	0.6	0.64
		0.70	0.6	0.64	0.7	0.75
		0.80	0.68	0.73	0.8	0.86
		0.90	0.77	0.82	0.9	0.97
		1.00	0.86	0.91	1.00	1.07
		1.20	1.03	1.10	1.20	1.29
		1.50	1.28	1.37	1.50	1.61
		2.00	1.28	1.37	1.50	1.61

Screws			Head or disc diameter d_w in [mm]			
			14	16	19	22
Pull-through resistance $N_{R,I,K}$ in [kN]	Component I: t_i in [mm], Aluminium Tensile strength $R_m \geq 215$ N/mm ²	0.50	0.56	0.6	0.65	0.7
		0.60	0.67	0.72	0.78	0.84
		0.70	0.78	0.83	0.91	0.98
		0.80	0.89	0.95	1.04	1.12
		0.90	1,00	1.07	1.17	1.26
		1.00	1.11	1.19	1.30	1.40
		1.20	1.34	1.43	1.56	1.68
		1.50	1.67	1.79	1.95	2.10
		2.00	1.67	1.79	1.95	2.10

Fastening screws JF

Pull-through Aluminium according EN-1999-1-4

Annex 4

Materials:
 Fastener: stainless steel (A2) – EN ISO 3506
 stainless steel (A4) – EN ISO 3506
 Washer: stainless steel (A2/A4) – EN ISO 3506
 Component I: S280GD to S350GD – EN 10346
 Component II: timber – EN 14081

Drilling capacity: $\Sigma t_i \leq 2 \times 1.00 \text{ mm}$

Timber substructures:
 performance determined with
 $M_{y,Rk} = 5.990 \text{ Nm}$ $l_b = 7 \text{ mm}$
 $f_{ax,k} = 15.300 \text{ N/mm}^2$ for $l_{ef} \geq 20 \text{ mm}$

$t_{N,i}$ [mm]	l_{ef} [mm]												
	20	23	25	28	30	33	35	38	40	43	45		
$V_{R,k}$ [kN] for $t_{N,i} =$	0.40	0.52	0.59	0.65	0.72	0.78	0.85	0.91	0.98	1.04	1.11	1.17	1.33
	0.50	0.52	0.59	0.65	0.72	0.78	0.85	0.91	0.98	1.04	1.11	1.17	1.70
	0.55	0.52	0.59	0.65	0.72	0.78	0.85	0.91	0.98	1.04	1.11	1.17	1.89
	0.63	0.52	0.59	0.65	0.72	0.78	0.85	0.91	0.98	1.04	1.11	1.17	2.19
	0.75	0.52	0.59	0.65	0.72	0.78	0.85	0.91	0.98	1.04	1.11	1.17	2.63
	0.88	0.52	0.59	0.65	0.72	0.78	0.85	0.91	0.98	1.04	1.11	1.17	3.11
	1.00	0.52	0.59	0.65	0.72	0.78	0.85	0.91	0.98	1.04	1.11	1.17	3.56
	1.13	—	—	—	—	—	—	—	—	—	—	—	—
	1.25	—	—	—	—	—	—	—	—	—	—	—	—
	1.50	—	—	—	—	—	—	—	—	—	—	—	—
	1.75	—	—	—	—	—	—	—	—	—	—	—	—
2.00	—	—	—	—	—	—	—	—	—	—	—	—	
$N_{R,k}$ [kN] for $t_{N,i} =$	0.40	0.95	0.95	0.95	0.95	0.95	0.95	0.95	0.95	0.95	0.95	0.95	0.95
	0.50	1.21	1.21	1.21	1.21	1.21	1.21	1.21	1.21	1.21	1.21	1.21	1.21
	0.55	1.35	1.35	1.35	1.35	1.35	1.35	1.35	1.35	1.35	1.35	1.35	1.35
	0.63	1.35	1.52	1.56	1.56	1.56	1.56	1.56	1.56	1.56	1.56	1.56	1.56
	0.75	1.35	1.52	1.69	1.86	1.87	1.87	1.87	1.87	1.87	1.87	1.87	1.87
	0.88	1.35	1.52	1.69	1.86	2.02	2.19	2.22	2.22	2.22	2.22	2.22	2.22
	1.00	1.35	1.52	1.69	1.86	2.02	2.19	2.36	2.53	2.53	2.53	2.53	2.53
	1.13	—	—	—	—	—	—	—	—	—	—	—	—
	1.25	—	—	—	—	—	—	—	—	—	—	—	—
	1.50	—	—	—	—	—	—	—	—	—	—	—	—
	1.75	—	—	—	—	—	—	—	—	—	—	—	—
2.00	—	—	—	—	—	—	—	—	—	—	—	—	

— The values indicated above depending on the screw depth l_{ef} , shall apply for $k_{mod} = 0.90$ and the timber strength class C24 ($\rho_k = 350 \text{ kg/m}^3$). For other values of k_{mod} and timber strength classes see Annex 3.

Fastening screws JF

Self-drilling screw (chipless)
JF3-(FR)-4.9xL, JF6-(FR)-4.9xL
 with hexagon head or round head with TX-drive system and sealing washer $\geq \text{Ø}11 \text{ mm}$

Annex 5

Materials:
 Fastener: stainless steel (A2) – EN ISO 3506
 stainless steel (A4) – EN ISO 3506
 Washer: stainless steel (A2/A4) – EN ISO 3506
 Component I: S280GD to S350GD – EN 10346
 Component II: timber – EN 14081

Drilling capacity: $\Sigma t_i \leq 2 \times 1.00 \text{ mm}$

Timber substructures:
 performance determined with
 $M_{y,Rk} = 5.990 \text{ Nm}$ $l_b = 7 \text{ mm}$
 $f_{ax,k} = 15.300 \text{ N/mm}^2$ for $l_{ef} \geq 20 \text{ mm}$

$t_{N,I}$ [mm]	l_{ef} [mm]												
	20	23	25	28	30	33	35	38	40	43	45		
$V_{R,k}$ [kN] for $t_{N,I} =$	0.40	0.52	0.59	0.65	0.72	0.78	0.85	0.91	0.98	1.04	1.11	1.17	1.33
	0.50	0.52	0.59	0.65	0.72	0.78	0.85	0.91	0.98	1.04	1.11	1.17	1.70
	0.55	0.52	0.59	0.65	0.72	0.78	0.85	0.91	0.98	1.04	1.11	1.17	1.89
	0.63	0.52	0.59	0.65	0.72	0.78	0.85	0.91	0.98	1.04	1.11	1.17	2.19
	0.75	0.52	0.59	0.65	0.72	0.78	0.85	0.91	0.98	1.04	1.11	1.17	2.63
	0.88	0.52	0.59	0.65	0.72	0.78	0.85	0.91	0.98	1.04	1.11	1.17	3.11
	1.00	0.52	0.59	0.65	0.72	0.78	0.85	0.91	0.98	1.04	1.11	1.17	3.56
	1.13	—	—	—	—	—	—	—	—	—	—	—	—
	1.25	—	—	—	—	—	—	—	—	—	—	—	—
	1.50	—	—	—	—	—	—	—	—	—	—	—	—
	1.75	—	—	—	—	—	—	—	—	—	—	—	—
2.00	—	—	—	—	—	—	—	—	—	—	—	—	
$N_{R,k}$ [kN] for $t_{N,I} =$	0.40	1.35	1.38	1.38	1.38	1.38	1.38	1.38	1.38	1.38	1.38	1.38	1.38
	0.50	1.35	1.52	1.69	1.77	1.77	1.77	1.77	1.77	1.77	1.77	1.77	1.77
	0.55	1.35	1.52	1.69	1.86	1.96	1.96	1.96	1.96	1.96	1.96	1.96	1.96
	0.63	1.35	1.52	1.69	1.86	2.02	2.19	2.27	2.27	2.27	2.27	2.27	2.27
	0.75	1.35	1.52	1.69	1.86	2.02	2.19	2.36	2.53	2.7	2.73	2.73	2.73
	0.88	1.35	1.52	1.69	1.86	2.02	2.19	2.36	2.53	2.7	2.87	3.04	3.23
	1.00	1.35	1.52	1.69	1.86	2.02	2.19	2.36	2.53	2.7	2.87	3.04	3.69
	1.13	—	—	—	—	—	—	—	—	—	—	—	—
	1.25	—	—	—	—	—	—	—	—	—	—	—	—
	1.50	—	—	—	—	—	—	—	—	—	—	—	—
	1.75	—	—	—	—	—	—	—	—	—	—	—	—
2.00	—	—	—	—	—	—	—	—	—	—	—	—	

— The values indicated above depending on the screw depth l_{ef} , shall apply for $k_{mod} = 0.90$ and the timber strength class C24 ($\rho_k = 350 \text{ kg/m}^3$). For other values of k_{mod} and timber strength classes see Annex 3.

Fastening screws JF

Self-drilling screw (chipless)
JF3-(FR)-4.9xL, JF6-(FR)-4.9xL
 with hexagon head or round head with TX-drive system and sealing washer $\geq \text{Ø}16 \text{ mm}$

Annex 6

Materials:

Fastener: stainless steel (A2) – EN ISO 3506
 stainless steel (A4) – EN ISO 3506

Washer: stainless steel (A2/A4) – EN ISO 3506
 with vulcanised EPDM seal

Component I: aluminium alloy
 with $R_{m,min} = 165 \text{ N/mm}^2$ – EN 573

Component II: timber – EN 14081

Drilling capacity: $\Sigma t_i \leq 2.00 \text{ mm}$

Timber substructures:
 performance determined with

$M_{y,Rk} = 5.990 \text{ Nm}$ $l_b = 7 \text{ mm}$
 $f_{ax,k} = 15.300 \text{ N/mm}^2$ for $l_{ef} \geq 20 \text{ mm}$

$t_{N,I}$ [mm]	l_{ef} [mm]										
	20	22	24	26	28	30	32	34	36		
$V_{R,k}$ [kN] for $t_{N,I} =$	0.50	0.50	0.50	0.50	0.50	0.50	0.50	0.50	0.50	0.50	bearing resistance of component I
0.60	0.52	0.57	0.62	0.66	0.66	0.66	0.66	0.66	0.66	0.66	
0.70	0.52	0.57	0.62	0.68	0.73	0.78	0.82	0.82	0.82	0.82	
0.80	0.52	0.57	0.62	0.68	0.73	0.78	0.83	0.88	0.94	0.98	
0.90	0.52	0.57	0.62	0.68	0.73	0.78	0.83	0.88	0.94	0.99	
1.00	0.52	0.57	0.62	0.68	0.73	0.78	0.83	0.88	0.94	1.00	
1.20	0.52	0.57	0.62	0.68	0.73	0.78	0.83	0.88	0.94	1.00	
1.50	0.52	0.57	0.62	0.68	0.73	0.78	0.83	0.88	0.94	1.00	
2.00	0.52	0.57	0.62	0.68	0.73	0.78	0.83	0.88	0.94	1.00	
$N_{R,II,k}$ [kN] =	1.35	1.48	1.62	1.75	1.89	2.02	2.16	2.29	2.43	pull-through resistance component I (see comment)	

- Pull-through resistance of component I according to EN 1999-1-4. chapter 8.3.3.1 or according to the specifications of the manufacturer of the aluminium profiles, see also Annex 4.
- The values indicated above depending on the screw depth l_{ef} shall apply to $k_{mod} = 0.90$ and the timber strength class C24 ($\rho_k = 350 \text{ kg/m}^3$). For other values of k_{mod} and strength classes see Annex 3.

Fastening screws JF	Annex 7
Self-drilling screw (chipless) JF3-(FR-)4.9xL, JF6-(FR-)4.9xL with hexagon head or round head with TX-drive system and sealing washer $\geq \varnothing 11 \text{ mm}$	

Materials:

Fastener: stainless steel (A2) – EN ISO 3506
 stainless steel (A4) – EN ISO 3506

Washer: stainless steel (A2/A4) – EN ISO 3506
 with vulcanised EPDM seal

Component I: aluminium alloy
 with $R_{m,min} = 165 \text{ N/mm}^2$ – EN 573

Component II: timber – EN 14081

Drilling capacity: $\Sigma t_i \leq 2.00 \text{ mm}$

Timber substructures:
 performance determined with

$M_{y,Rk} = 5.990 \text{ Nm}$ $l_b = 7 \text{ mm}$
 $f_{ax,k} = 15.300 \text{ N/mm}^2$ for $l_{ef} \geq 20 \text{ mm}$

$t_{N,i}$ [mm]	l_{ef} [mm]										
	20	22	24	26	28	30	32	34	36		
$V_{R,k}$ [kN] for $t_{N,i} =$	0.50	0.50	0.50	0.50	0.50	0.50	0.50	0.50	0.50	0.50	bearing resistance of component I
0.60	0.52	0.57	0.62	0.66	0.66	0.66	0.66	0.66	0.66	0.66	
0.70	0.52	0.57	0.62	0.68	0.73	0.78	0.82	0.82	0.82	0.82	
0.80	0.52	0.57	0.62	0.68	0.73	0.78	0.83	0.88	0.94	0.98	
0.90	0.52	0.57	0.62	0.68	0.73	0.78	0.83	0.88	0.94	0.99	
1.00	0.52	0.57	0.62	0.68	0.73	0.78	0.83	0.88	0.94	1.00	
1.20	0.52	0.57	0.62	0.68	0.73	0.78	0.83	0.88	0.94	1.00	
1.50	0.52	0.57	0.62	0.68	0.73	0.78	0.83	0.88	0.94	1.00	
2.00	0.52	0.57	0.62	0.68	0.73	0.78	0.83	0.88	0.94	1.00	
$N_{R,II,k}$ [kN] =	1.35	1.48	1.62	1.75	1.89	2.02	2.16	2.29	2.43	pull-through resistance component I (see comment)	

- Pull-through resistance of component I according to EN 1999-1-4. chapter 8.3.3.1 or according to the specifications of the manufacturer of the aluminium profiles, see also Annex 4.
- The values indicated above depending on the screw depth l_{ef} shall apply to $k_{mod} = 0.90$ and the timber strength class C24 ($\rho_k = 350 \text{ kg/m}^3$). For other values of k_{mod} and strength classes see Annex 3.

Fastening screws JF	Annex 8
Self-drilling screw (chipless) JF3-(FR)-4.9xL, JF6-(FR)-4.9xL with hexagon head or round head with TX-drive system and sealing washer $\geq \phi 16 \text{ mm}$	

Materials:

Fastener: stainless steel (A2) – EN ISO 3506
stainless steel (A4) – EN ISO 3506

Washer: stainless steel (A2/A4) – EN ISO 3506
with vulcanised EPDM seal

Component I: aluminium alloy
with $R_{m,min} = 215 \text{ N/mm}^2$ – EN 573

Component II: timber – EN 14081

Drilling capacity: $\Sigma t_i \leq 2.00 \text{ mm}$

Timber substructures:
performance determined with

$M_{y,Rk} = 5.990 \text{ Nm}$ $l_b = 7 \text{ mm}$
 $f_{ax,k} = 15.300 \text{ N/mm}^2$ for $l_{ef} \geq 20 \text{ mm}$

$t_{N,I}$ [mm]	l_{ef} [mm]										
	20	22	24	26	28	30	32	34	36		
$V_{R,k}$ [kN] for $t_{N,I} =$	0.52	0.57	0.62	0.66	0.66	0.66	0.66	0.66	0.66	0.66	bearing resistance of component I
0.60	0.52	0.57	0.62	0.68	0.73	0.78	0.83	0.87	0.87	0.87	
0.70	0.52	0.57	0.62	0.68	0.73	0.78	0.83	0.88	0.94	1.07	
0.80	0.52	0.57	0.62	0.68	0.73	0.78	0.83	0.88	0.94	1.28	
0.90	0.52	0.57	0.62	0.68	0.73	0.78	0.83	0.88	0.94	1.29	
1.00	0.52	0.57	0.62	0.68	0.73	0.78	0.83	0.88	0.94	1.30	
1.20	0.52	0.57	0.62	0.68	0.73	0.78	0.83	0.88	0.94	1.30	
1.50	0.52	0.57	0.62	0.68	0.73	0.78	0.83	0.88	0.94	1.30	
2.00	0.52	0.57	0.62	0.68	0.73	0.78	0.83	0.88	0.94	1.30	
$N_{R,II,k}$ [kN] =	1.35	1.48	1.62	1.75	1.89	2.02	2.16	2.29	2.43	pull-through resistance component I (see comment)	

- Pull-through resistance of component I according to EN 1999-1-4. chapter 8.3.3.1 or according to the specifications of the manufacturer of the aluminium profiles, see also Annex 4.
- The values indicated above depending on the screw depth l_{ef} shall apply to $k_{mod} = 0.90$ and the timber strength class C24 ($\rho_k = 350 \text{ kg/m}^3$). For other values of k_{mod} and strength classes see Annex 3.

Fastening screws JF

Self-drilling screw (chipless)
JF3-(FR-)4.9xL, JF6-(FR-)4.9xL
 with hexagon head or round head with TX-drive system and sealing washer $\geq \phi 16 \text{ mm}$

Annex 10

	<p>Materials:</p> <p>Fastener: stainless steel (A2) – EN ISO 3506 stainless steel (A4) – EN ISO 3506</p> <p>Washer: stainless steel (A2/A4) – EN ISO 3506 with vulcanised EPDM seal</p> <p>Component I: S280GD to S350GD – EN 10346 Component II: S280GD to S350GD – EN 10346</p>
<p>Drilling capacity: $\Sigma t_i \leq 2 \times 1.00 \text{ mm}$</p>	<p>Timber substructures:</p> <p>No properties noted</p>

$t_{N,II}$ [mm]	0.40	0.50	0.55	0.63	0.75	0.88	1.00
$V_{R,k}$ [kN] for $t_{N,I} =$							
0.40	0.88	0.88	0.88	0.88	0.88	0.88	0.88
0.50	0.88	1.56	1.56	1.56	1.56	1.56	1.56
0.55	0.88	1.56	1.76	1.76	1.76	1.76	1.76
0.63	0.88	1.56	1.76	2.09	2.09	2.09	2.09
0.75	0.88	1.56	1.76	2.09	2.57	2.57	2.57
0.88	0.88	1.56	1.76	2.09	2.57	3.11	3.11
1.00	0.88	1.56	1.76	2.09	2.57	3.11	3.61
1.13	—	—	—	—	—	—	—
1.25	—	—	—	—	—	—	—
$N_{R,k}$ [kN] for $t_{N,I} =$							
0.40	0.60	0.82	0.94	1.00	1.00	1.00	1.00
0.50	0.60	0.82	0.94	1.14	1.44	1.67	1.67
0.55	0.60	0.82	0.94	1.14	1.44	1.80	1.87
0.63	0.60	0.82	0.94	1.14	1.44	1.80	2.14
0.75	0.60	0.82	0.94	1.14	1.44	1.80	2.14
0.88	0.60	0.82	0.94	1.14	1.44	1.80	2.14
1.00	0.60	0.82	0.94	1.14	1.44	1.80	2.14
1.13	—	—	—	—	—	—	—
1.25	—	—	—	—	—	—	—
$N_{R,II,k}$ [kN] =	0.60	0.82	0.94	1.14	1.44	1.80	2.14

– If component I and II made of S320GD or S350GD. all values can be increased by 8.3%.

Fastening screws JF

Self-drilling screw (chipless)
JF3-(FR/LT-)2-6.0xL, JF6-(FR/LT-)2-6.0xL
 with hexagon head or round head with TX-drive system and sealing washer $\geq \text{Ø}11 \text{ mm}$

Annex 11

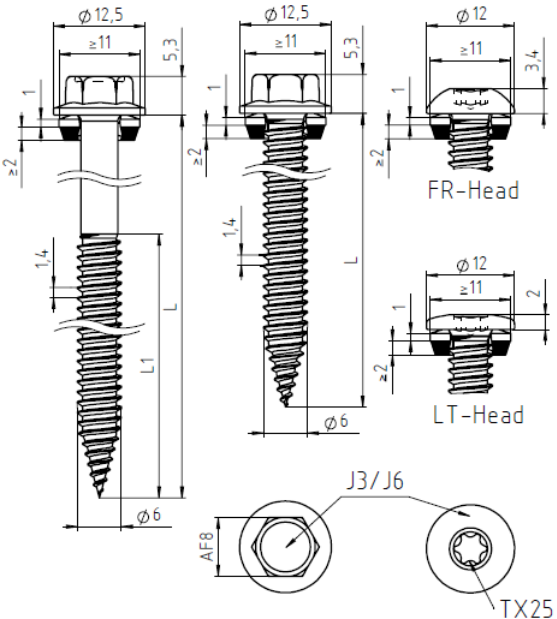

Materials:
 Fastener: stainless steel (A2) – EN ISO 3506
 stainless steel (A4) – EN ISO 3506
 Washer: stainless steel (A2/A4) – EN ISO 3506
 with vulcanised EPDM seal
 Component I: S280GD to S350GD – EN 10346
 Component II: S280GD to S350GD – EN 10346

Drilling capacity: $\Sigma t_i \leq 2 \times 1.00 \text{ mm}$

Timber substructures:
 No properties noted

$t_{N,II}$ [mm]	0.40	0.50	0.55	0.63	0.75	0.88	1.00
$V_{R,k}$ [kN] for $t_{N,I} =$	0.40	0.96	0.96	0.96	0.96	0.96	0.96
	0.50	0.96	1.56	1.56	1.56	1.56	1.56
	0.55	0.96	1.56	1.76	1.76	1.76	1.76
	0.63	0.96	1.56	1.76	2.09	2.09	2.09
	0.75	0.96	1.56	1.76	2.09	2.57	2.57
	0.88	0.96	1.56	1.76	2.09	2.57	3.11
	1.00	0.96	1.56	1.76	2.09	2.57	3.61
	1.13	—	—	—	—	—	—
	1.25	—	—	—	—	—	—
$N_{R,k}$ [kN] for $t_{N,I} =$	0.40	0.60	0.82	0.94	1.14	1.44	1.46
	0.50	0.60	0.82	0.94	1.14	1.44	1.76
	0.55	0.60	0.82	0.94	1.14	1.44	1.80
	0.63	0.60	0.82	0.94	1.14	1.44	1.80
	0.75	0.60	0.82	0.94	1.14	1.44	1.80
	0.88	0.60	0.82	0.94	1.14	1.44	1.80
	1.00	0.60	0.82	0.94	1.14	1.44	1.80
	1.13	—	—	—	—	—	—
	1.25	—	—	—	—	—	—
$N_{R,II,k}$ [kN] =	0.60	0.82	0.94	1.14	1.44	1.80	2.14

– If component I and II made of S320GD or S350GD. all values can be increased by 8.3%.

Fastening screws JF

Self-drilling screw (chipless)
JF3-(FR/LT-)2-6.0xL, JF6-(FR/LT-)2-6.0xL
 with hexagon head or round head with TX-drive system and sealing washer $\geq \text{Ø}14 \text{ mm}$

Annex 12

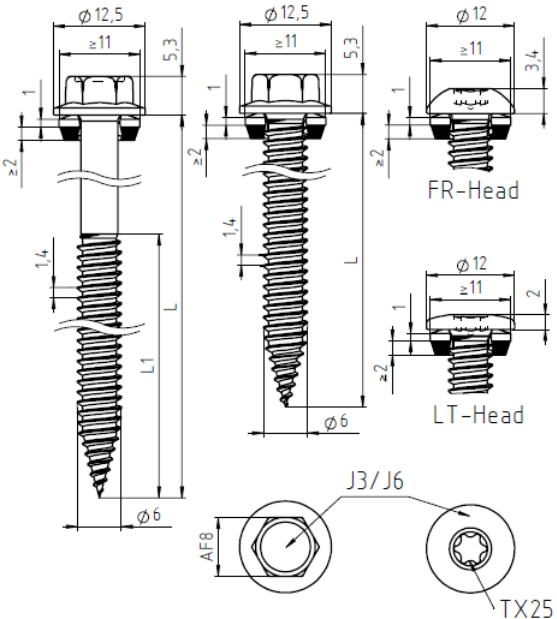

Materials:

Fastener: stainless steel (A2) – EN ISO 3506
stainless steel (A4) – EN ISO 3506

Washer: stainless steel (A2/A4) – EN ISO 3506
with vulcanised EPDM seal

Component I: aluminium alloy
with $R_{m,min} = 165 \text{ N/mm}^2$ – EN 573

Component II: aluminium alloy
with $R_{m,min} = 165 \text{ N/mm}^2$ – EN 573

Drilling capacity: $\Sigma t_i \leq 2 \times 1.00 \text{ mm}$

Timber substructures:

No properties noted

$t_{N,II}$ [mm]	0.40	0.50	0.60	0.70	0.80	0.90	1.00	1.20	1.50
$V_{R,k}$ [kN] for $t_{N,I} =$									
0.40	0.43	0.43	0.43	0.43	0.43	0.43	0.43	0.43	0.43
0.50	0.43	0.62	0.62	0.62	0.62	0.62	0.62	0.62	0.62
0.60	0.43	0.62	0.71	0.71	0.71	0.71	0.71	0.71	0.71
0.70	0.43	0.62	0.71	0.79	0.79	0.79	0.79	0.79	0.79
0.80	0.43	0.62	0.71	0.79	0.88	0.88	0.88	0.88	0.88
0.90	0.43	0.62	0.71	0.79	0.88	1.04	1.04	1.04	1.04
1.00	0.43	0.62	0.71	0.79	0.88	1.04	1.19	0.88	0.88
1.20	0.43	0.62	0.71	0.79	0.88	1.04	1.19	1.24	1.24
1.50	0.43	0.62	0.71	0.79	0.88	1.04	1.19	1.24	1.87
$N_{R,II,k}$ [kN] =	0.24	0.35	0.45	0.58	0.69	0.80	0.91	1.13	1.63

– Pull-through resistance of component I according to EN 1999-1-4. chapter 8.3.3.1 or according to the specifications of the manufacturer of the aluminium profiles, see also Annex 4.

Fastening screws JF

Self-drilling screw (chipless)
JF3-(FR/LT-)2-6.0xL, JF6-(FR/LT-)2-6.0xL
 with hexagon head or round head with TX-drive system and sealing washer $\geq \text{Ø}11\text{mm}$

Annex 13

	<p>Materials:</p> <p>Fastener: stainless steel (A2) – EN ISO 3506 stainless steel (A4) – EN ISO 3506</p> <p>Washer: stainless steel (A2/A4) – EN ISO 3506 with vulcanised EPDM seal</p> <p>Component I: aluminium alloy with $R_{m,min} = 215 \text{ N/mm}^2$ – EN 573</p> <p>Component II: aluminium alloy with $R_{m,min} = 215 \text{ N/mm}^2$ – EN 573</p> <hr/> <p>Drilling capacity: $\Sigma t_i \leq 2 \times 1.00 \text{ mm}$</p> <hr/> <p>Timber substructures:</p> <p>No properties noted</p>
--	---

$t_{N,II}$ [mm]	0.40	0.50	0.60	0.70	0.80	0.90	1.00	1.20	1.50
$V_{R,k}$ [kN] for $t_{N,I} =$									
0.40	0.55	0.55	0.55	0.55	0.55	0.55	0.55	0.55	0.55
0.50	0.55	0.79	0.79	0.79	0.79	0.79	0.79	0.79	0.79
0.60	0.55	0.79	0.91	0.91	0.91	0.91	0.91	0.91	0.91
0.70	0.55	0.79	0.91	1.03	1.03	1.03	1.03	1.03	1.03
0.80	0.55	0.79	0.91	1.03	1.15	1.15	1.15	1.15	1.15
0.90	0.55	0.79	0.91	1.03	1.15	1.35	1.35	1.35	1.35
1.00	0.55	0.79	0.91	1.03	1.15	1.35	1.54	1.54	1.54
1.20	0.55	0.79	0.91	1.03	1.15	1.35	1.54	1.62	1.62
1.50	0.55	0.79	0.91	1.03	1.15	1.35	1.54	1.62	2.44
$N_{R,II,k}$ [kN] =	0.31	0.46	0.60	0.75	0.89	1.04	1.18	1.47	2.12

- Pull-through resistance of component I according to EN 1999-1-4. chapter 8.3.3.1 or according to the specifications of the manufacturer of the aluminium profiles, see also Annex 4.

Fastening screws JF

Self-drilling screw (chipless)
JF3-(FR/LT-)2-6.0xL, JF6-(FR/LT-)2-6.0xL
 with hexagon head or round head with TX- drive system and sealing washer $\geq \varnothing 14 \text{ mm}$

Annex 14

	<p>Materials:</p> <p>Fastener: stainless steel (A2) – EN ISO 3506 stainless steel (A4) – EN ISO 3506</p> <p>Washer: stainless steel (A2/A4) – EN ISO 3506 with vulcanised EPDM seal</p> <p>Component I: aluminium alloy with $R_{m,min} = 215 \text{ N/mm}^2$ – EN 573</p> <p>Component II: S280GD bis S350GD – EN 10346</p>
<p>Drilling capacity: $\Sigma t_i \leq 1.50 \text{ mm} + 1.00 \text{ mm}$</p>	<p>Timber substructures:</p> <p>No properties noted</p>

$t_{N,II}$ [mm]	0.40	0.50	0.55	0.63	0.75	0.88	1.00
$V_{R,k}$ [kN] for $t_{N,I} =$							
0.40	0.55	0.55	0.55	0.55	0.55	0.55	0.55
0.50	0.55	0.79	0.79	0.79	0.79	0.79	0.79
0.60	0.55	0.79	0.85	0.85	0.91	0.91	0.91
0.70	0.55	0.79	0.85	0.85	0.95	1.14	1.14
0.80	0.55	0.79	0.85	0.85	0.95	1.42	1.42
0.90	0.55	0.79	0.85	0.85	0.95	1.42	1.90
1.00	0.55	0.79	0.85	0.85	0.95	1.42	2.38
1.20	0.55	0.79	0.85	0.85	0.95	1.42	2.38
1.50	0.55	0.79	0.85	0.85	0.95	1.42	2.38
$N_{R,II,k}$ [kN] =	0.60	0.82	0.94	1.14	1.44	1.80	2.14

- Pull-through resistance of component I according to EN 1999-1-4, chapter 8.3.3.1 or according to the specifications of the manufacturer of the aluminium profiles, see also Annex 4.

Fastening screws JF

Self-drilling screw (chipless)
JF3-(FR/LT-)2-6.0xL, JF6-(FR/LT-)2-6.0xL
 with hexagon head or round head with TX-drive system and sealing washer $\geq \text{Ø}14 \text{ mm}$

Annex 15